



Selection: Semi-hermetic Screw Compressors HS

Input Values

Compressor model	HSN7471-75	Operating mode	Standard
Refrigerant	R404A	Power supply	400V-3-50Hz
Reference temperature	Dew point temp.	Useful superheat	100%
Liq. subc. (in condenser)	0 K	Additional cooling	Automatic
Suct. gas superheat	10,00 K	Max. discharge gas temp.	80,0 °C

Result

Q [W]	Cooling capacity	mHP [kg/h]	Mass flow HP
P [kW]	Power input	Qac [kW]	Additional cooling
I [A]	Current	tcu [°C]	Liquid temp.
COP [-]	COP/EER	pm [bar(a)]	ECO pressure
mLP [kg/h]	Mass flow LP	Qsc [kW]	sub cooler capacity (ECO)

tc	to	-15°C	-20°C	-25°C	-30°C	-35°C	-40°C	-45°C	-50°C
30°C	Q [W]	134659	108924	87160	68884	53656	41077	30788	22462
	P [kW]	51,4	48,2	45,2	42,4	39,8	37,4	35,1	33,1
	I [A]	82,7	78,0	73,6	69,4	65,6	62,1	59,0	56,1
	COP [-]	2,62	2,26	1,93	1,62	1,35	1,10	0,88	0,68
	mLP [kg/h]	3934	3262	2678	2174	1741	1372	1059	797
	mHP [kg/h]	3934	3262	2678	2174	1741	1372	1059	797
	Qac [kW]	--	--	--	--	0,73	5,37	9,47	13,06
	tcu [°C]	29,6	29,6	29,6	29,6	29,6	29,6	29,6	29,6
	pm [bar(a)]	--	--	--	--	--	--	--	--
	Qsc [kW]	--	--	--	--	--	--	--	--
40°C	Q [W]	114721	92300	73423	57650	44581	33855	25145	--
	P [kW]	59,4	55,8	52,4	49,2	46,4	43,9	41,9	--
	I [A]	94,7	89,3	84,2	79,5	75,3	71,6	68,6	--
	COP [-]	1,93	1,65	1,40	1,17	0,96	0,77	0,60	--
	mLP [kg/h]	3857	3193	2616	2119	1693	1330	1023	--
	mHP [kg/h]	3857	3193	2616	2119	1693	1330	1023	--
	Qac [kW]	--	--	1,71	6,36	10,68	14,69	18,48	--
	tcu [°C]	39,6	39,6	39,6	39,6	39,6	39,6	39,6	--
	pm [bar(a)]	--	--	--	--	--	--	--	--
	Qsc [kW]	--	--	--	--	--	--	--	--
50°C	Q [W]	92430	73661	57942	44884	34136	25381	18331	--
	P [kW]	69,2	65,3	61,6	58,2	55,4	53,2	51,9	--
	I [A]	109,4	103,5	97,9	92,9	88,6	85,4	83,4	--
	COP [-]	1,33	1,13	0,94	0,77	0,62	0,48	0,35	--
	mLP [kg/h]	3710	3059	2494	2006	1587	1230	928	--
	mHP [kg/h]	3710	3059	2494	2006	1587	1230	928	--
	Qac [kW]	10,32	14,17	17,77	21,3	24,7	28,4	32,3	--
	tcu [°C]	49,7	49,7	49,7	49,7	49,7	49,7	49,7	--
	pm [bar(a)]	--	--	--	--	--	--	--	--
	Qsc [kW]	--	--	--	--	--	--	--	--

-- No calculation possible (see message in single point selection)

*According to EN12900 (10K suction gas superheat, 0K liquid subcooling)

Application Limits Standard HSN7471-75

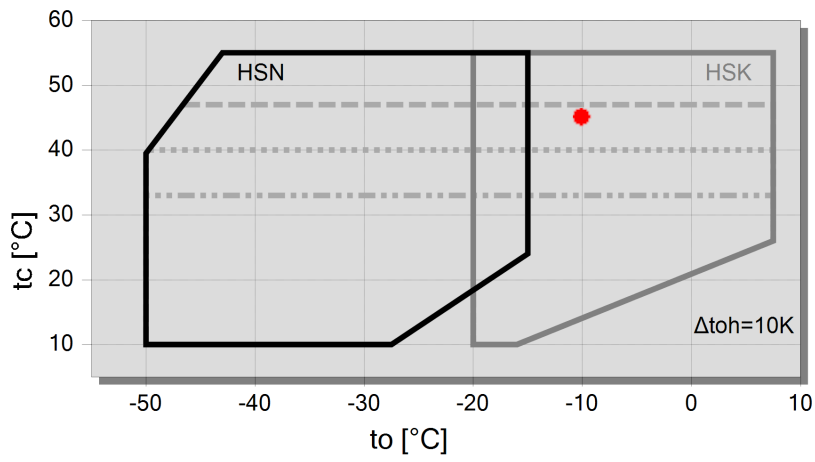

Legend

- max. tc for frequencies = 20Hz
- max. tc for frequencies = 25Hz
- max. tc for frequencies = 35Hz
- A



Technical Data: HSN7471-75

Dimensions and Connections

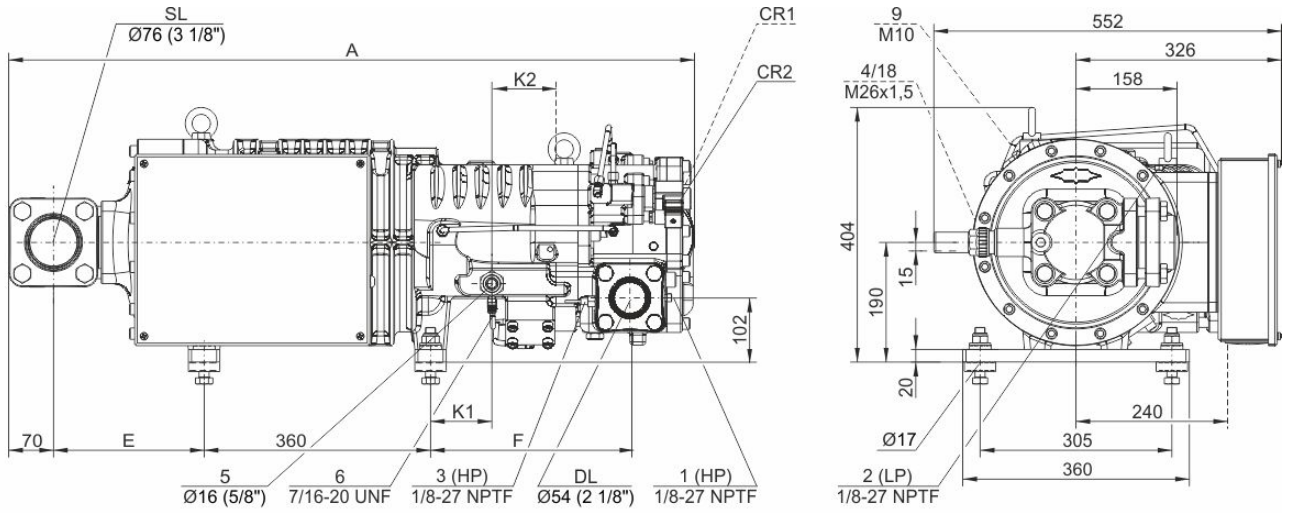

Model	A	E	F	K1	K2
	mm	mm	mm	mm	mm
HS.7451, HS.7461	1021	186	295	76	109
HSK7471-70, HSN7471-75	1034	186	318	98	97
HSK7471-90	1087	238	318	98	97



Technical Data

Technical Data

Displacement (2900 RPM 50 Hz)	250 m ³ /h
Displacement (3500 RPM 60 Hz)	302 m ³ /h
Weight	326 kg
Max. pressure (LP/HP)	19 / 28 bar
Connection suction line	76 mm - 3 1/8"
Connection discharge line	54 mm - 2 1/8"
Adapter/shut-off valve for ECO	22 mm - 7/8" (Option)
Oil type R22	B150SH, B100 (Option)
Oil type R134a/R404A/R507A/R407A/R407F	BSE170
Oil type R448A/R449A/R454C	BSE170

Motor data

Motor version	1
Motor voltage (more on request)	380-415V PW-3-50Hz
Max operating current	144.0 A
Starting current (Rotor locked)	350.0 A D / 585.0 A DD
Max. Power input	85,0 kW

Extent of delivery (Standard)

Discharge gas temperature sensor	Standard
Start unloading	Standard
Oil flow control	SE-B3 (Standard)
Motor protection	SE-E1 (Standard), SE-E3 (Standard for 660-690V)
Suction shut-off valve	Standard
Capacity control	100-75-50% (Standard)
Enclosure class	IP54

Available Options

Discharge shut-off valve	Option
ECO connection with shut-off valve	Option
Motor protection	SE-i1 (200-690V)

Sound measurement

Sound power level (-35°C / 40°C)	87,5 dB(A)
Sound pressure level @ 1m (-35°C / 40°C)	79,5 dB(A)



Semi-hermetic Screw Compressors HS

HSK = Application for air-conditioning and medium temperature cooling.

HSN = Application for low temperature cooling.

Notes regarding application limits (see "Limits")

- * Ranges are valid for standard operation and at full-load conditions.
- * With high pressure conditions, part-load operation is partly limited (see application limits in applications manual SH-100).
- * With Economizer operation the maximum admissible evaporation temperature is shifted by 10K downward (otherwise there is a danger of excessive compression and overload of the motor because of a higher mass flow). At pull-down conditions from higher evaporation temperatures, the ECO injection must remain closed until the evaporation temperature is below the maximum admissible value and a stable operation is achieved (e.g. control of the ECO solenoid valve by means of a low pressure cut-out). The use of the ECO-system with higher evaporation temperatures requires individual consultation with Bitzer.

HS 64/74

- * Capacity control with ECO operation at the same time is limited to one single regulating step (CR 75%). At CR 50% the ECO injection should be closed.

Data for sound emission

Data are based on 50Hz application (IP-units 60Hz) and R404A.

Sound pressure level: values are based on open air test sites with semi-spherical sound emissions at 1 meter distance. For further information see Technical Information "Sound Data".

Legend of connection positions according to "Dimensions":

- 1 High pressure connection (HP)
Connection for high pressure switch (HP)
- 1a Additional high pressure connection (HP)
Not suitable for pressure switch or pressure transmitter!
- 1b Connection for high pressure transmitter (HP)
- 2 Low pressure connection (LP)
Connection for low pressure switch
- 2a Additional low pressure connection (LP)
- 2b Connection for low pressure transmitter (LP)
- 2c Low pressure connection for the minimum pressure differential control valve
- 3 Connection for discharge gas temperature sensor (HP)
- 4 Connection for economiser (ECO)
HS.85: ECO valve with connection line (option)
OS.85, OS.95, OS.105, HS.95: ECO valve (option)
- 5 Connection/valve for oil injection
- 6 Oil pressure connection
- 7 Oil drain (compressor or motor housing)
- 7a Oil drain (suction gas filter)
- 7b Oil drain from shaft seal (maintenance connection)
- 7c Oil drain hose (shaft seal)
- 8 Threaded bore for foot fastening
- 9 Threaded bore for pipe fixture (ECO and LI lines)
- 10 Maintenance connection for oil filter
- 11 Oil drain (oil filter)
- 13 Oil filter monitoring
- 14 Oil flow switch
- 15 Earth screw for housing
- 16 Pressure blow-off (oil filter chamber)
- 17 Maintenance connection for shaft seal
- 18 Liquid injection (LI)
- 19 Compressor module
- 20 Slider position indicator
- 21 Oil level switch
- 22 Oil pressure transmitter



- 23 Connection for oil and gas return (for systems with flooded evaporator adaptor optional)
- 24 Access to oil circulation restrictor
- 25 Oil inlet for shaft seal cooling
- 26 Oil outlet for shaft seal cooling
- 27 Temperature sensor in the shaft seal
- 28 Vibration sensor connection
- SL Suction gas line
- DL Discharge gas line

Dimensions can show tolerances according to EN ISO 13920-B.